

OLLI Printed Book Week 6

**The Industrial Revolution
and related developments**

**Preindustrial changes in paper
manufacture: “wove” paper —
still handmade but without
visible chain lines and laid lines**

James Whatman the Elder

1702–1759. Introduced wove paper, made using moulds with a mesh of wire woven like a textile instead of laid lines and chain lines.

John Baskerville

1707-1775, based in Birmingham!

(Licensing Act had lapsed in 1695.)

Active in printing from mid-1750s.

Multitalented artisan-manufacturer.

Friend of Benjamin Franklin.

PUBLII VIRGILII

MARONIS

BUCOLICA,

GEORGICA,

E T

AE NE I S.

BIRMINGHAMIAE:

Typis JOHANNIS BASKERVILLE.

MDCCLVII.

P. VIRGILII MARONIS

AE NE I D O S

LIBER SECUNDUS.

CONTIGUERE omnes, intentique ora tenebant:
Inde toro pater Aeneas sic orfus ab alto:
Infandum, Regina, jubes renovare dolorem;
Trojanas ut opes, et lamentabile regnum
5 Eruerint Danaï: quæque ipse miserrima vidi,
Et quorum pars magna fui. quis talia fando,
Myrmidonum, Dolopumve, aut duri miles Ulyssæi,
Temperet a lacrymis? et jam nox humida cœlo
Præcipitat, suadentque cadentia fidera somnos.
10 Sed, si tantus amor casus cognoscere nostros,
Et breviter Trojæ supremum audire laborem;
Quamquam animus meminisse horret, luctuque refugit,
Incipiam. Fracti bello, fatisque repulsi
Ductores Danaum, tot jam labentibus annis,
15 Instar montis equum, divina Palladis arte
Aedificant; sectaque intexunt abiete costas.
Votum pro reditu simulant: ea fama vagatur.
Huc delecta virum fortiti corpora furtim
Includunt cæco lateri; penitusque cavernas
20 Ingentes, utrumque armato milite complent.
Est in conspectu Tenedos, notissima fama
Insula, dives opum, Priami dum regna manebant:
Nunc tantum sinus, et statio malefida carinis.

Huc



Baskerville's 1757 edition of Virgil: His own typeface and James Whatman's wove paper — the first known use of wove paper — “glazed” by Baskerville. Plates are from a 1654 edition!

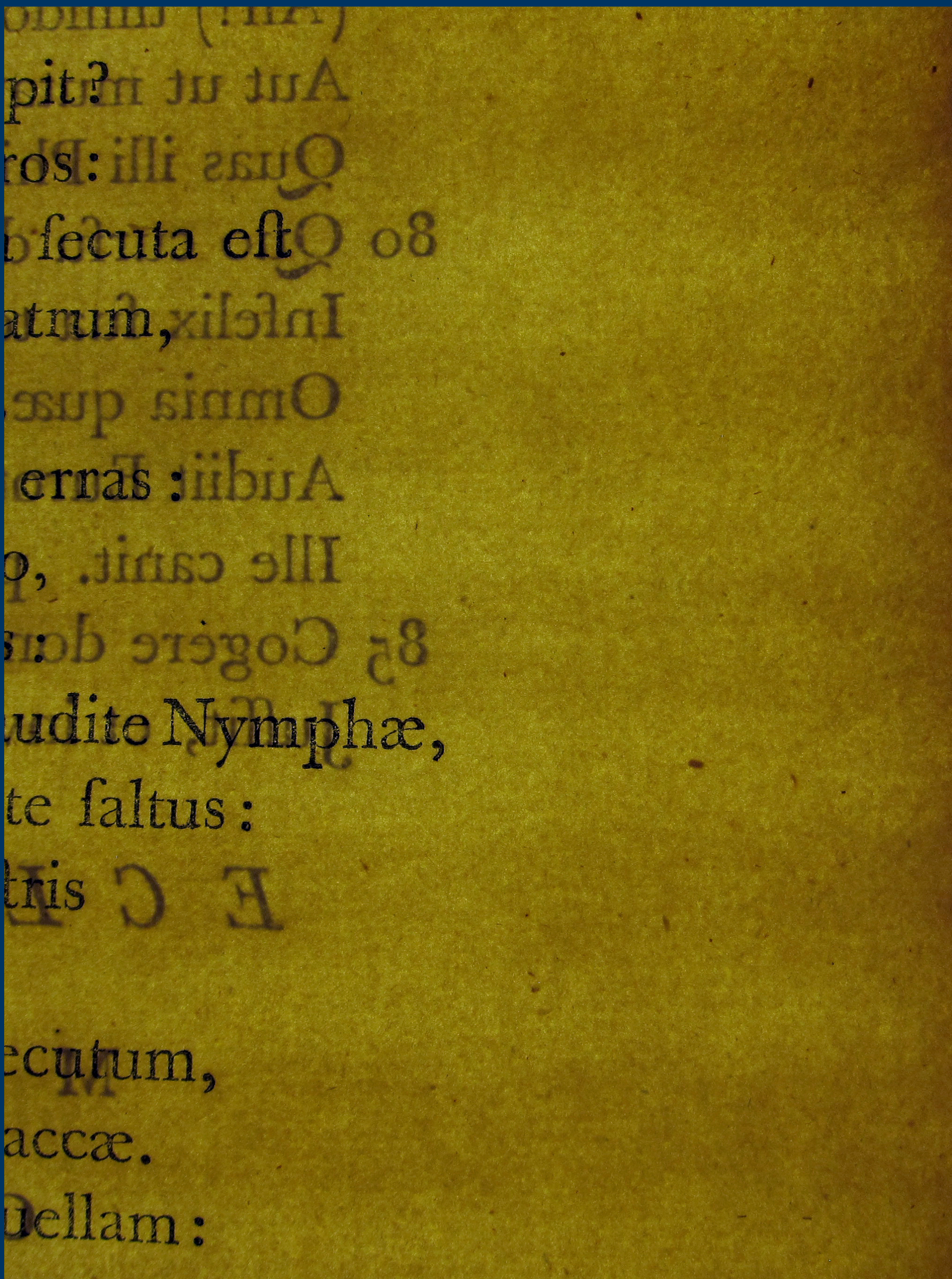

**Baskerville's
1757 Virgil:
the new
wove paper,
left, and
normal
paper, right,
seen with
light shining
through**

VIRGILII
RONIS
OLICA,
RGICA,

Image reproduction techniques

1. Reproducing type and images

2. Printmaking techniques

Stereotyping

A mold is taken of a forme of set type, using plaster of Paris, papier mâché, or similar material, and then metal is cast in that mold.

Right: making a stereotype mold or “flong” from layers of paper.

Invented early 18th c. but became viable on a large scale in early 19th c.



Stereotyping, cont'd.

Books can then be printed from the stereotype plates instead of having to reset type, allowing printers to keep books “in print” without additional costly investment in type.

Experimental in the 18th c., normal in the 19th. Worthwhile when there is likely to be consistent demand for a book over time.

In 19th c. America, specialist stereotyping houses arose that would typeset and stereotype pages and sell the plates to printers in other cities.

Electrotyping

Similar concept, but using electrical conductivity to form a copper layer over a mold. Invented ca. 1840 and in the 19th c. used mainly to make copper plates of existing images.

Printmaking techniques

Older INTAGLIO methods:

Engraving or etching on metal plates, usually copper; Mezzotint popular in 18th c.

Newer RELIEF methods

Wood “engraving”: Thomas Bewick’s late-18th c. improvement: cut against the grain for much finer detail than previously possible. Used by Doré (1828-1883).

Linocuts (20th c.)

PLANOGRAPHY

Lithography (invented 1819; normal for printing maps from 1850s)

Wood “engraving” – a relief method, unlike earlier woodblock printing.

The Elephant by Thomas Bewick (1753-1828). Woodblock used in p.186 of the 1791 Newcastle edition of the General History of Quadrupeds, from McGill University Special Collections

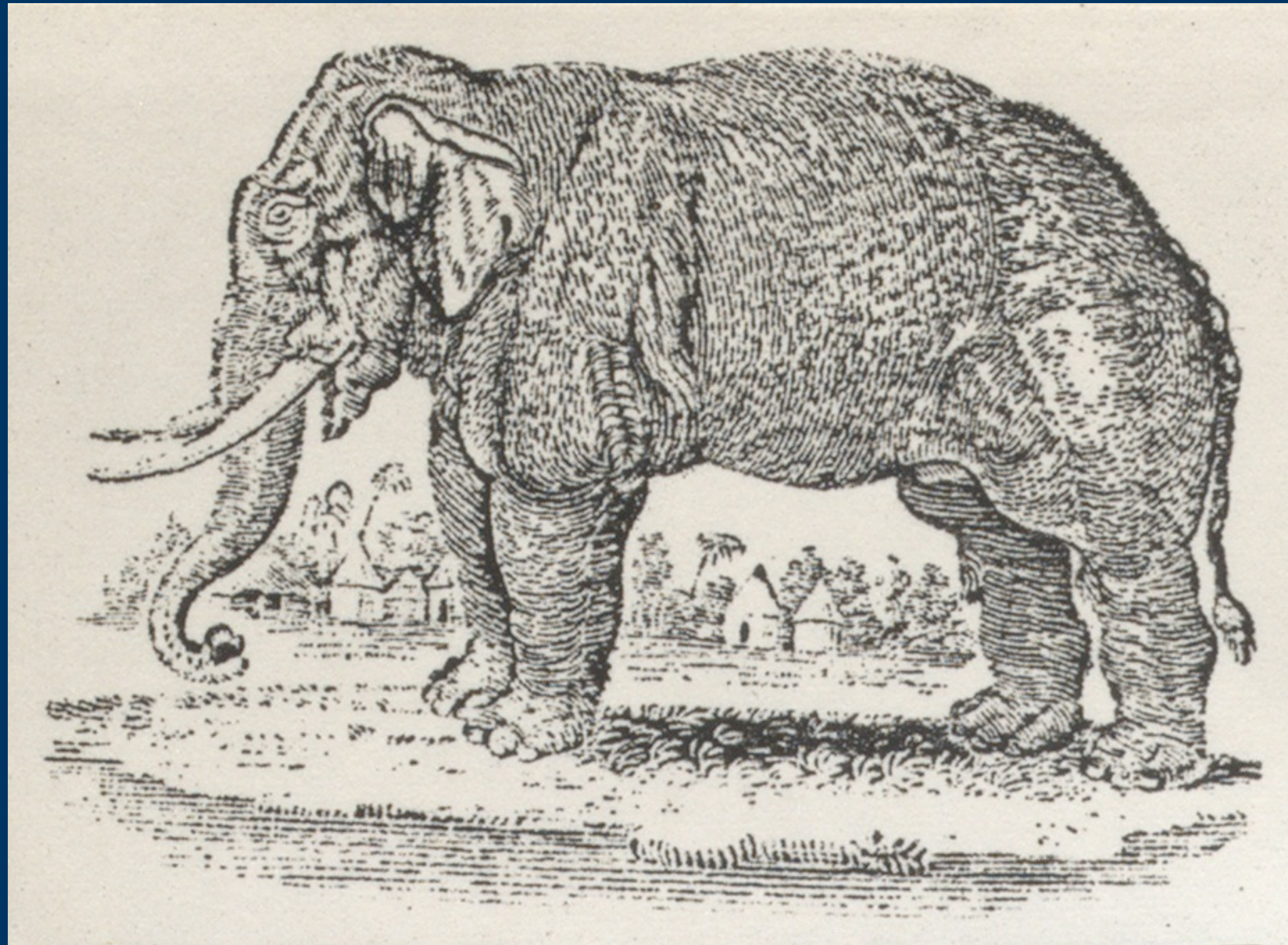

Gustave Doré (1832-1883)
used Bewick's wood
engraving method.



**Bonus Doré:
Ezekiel in the
valley of the dry
bones (detail)**



**19th-century developments
in book production:
paper, presses, binding**

Machine papermaking: the Fourdrinier machine

Invented in France 1799 by Louis-Nicholas Robert; patented in England by Fourdrinier shortly thereafter.

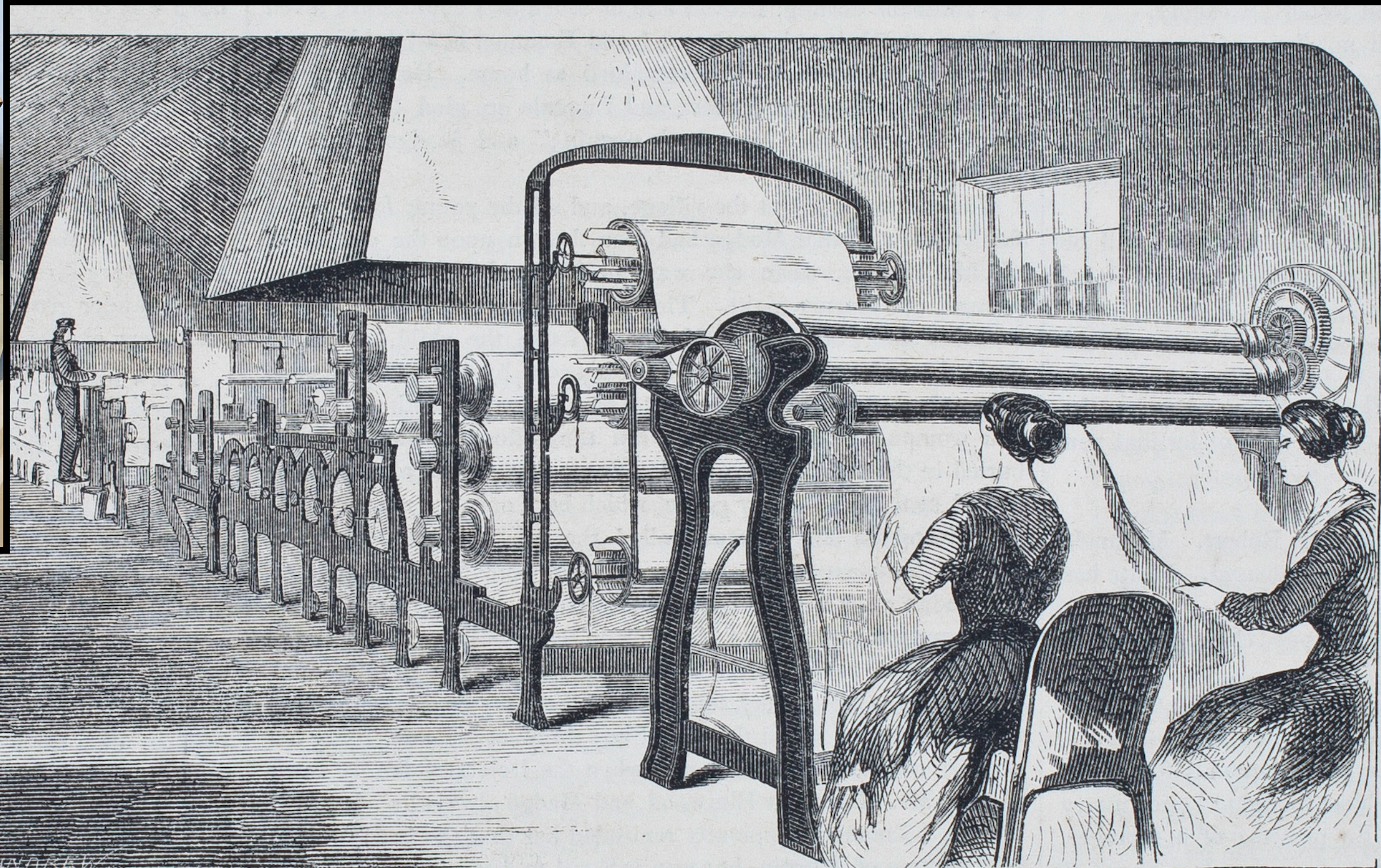

Model of hand-cranked original above; huge steam-driven mid-19th-century model at right.

FOUDRINIER MACHINE.

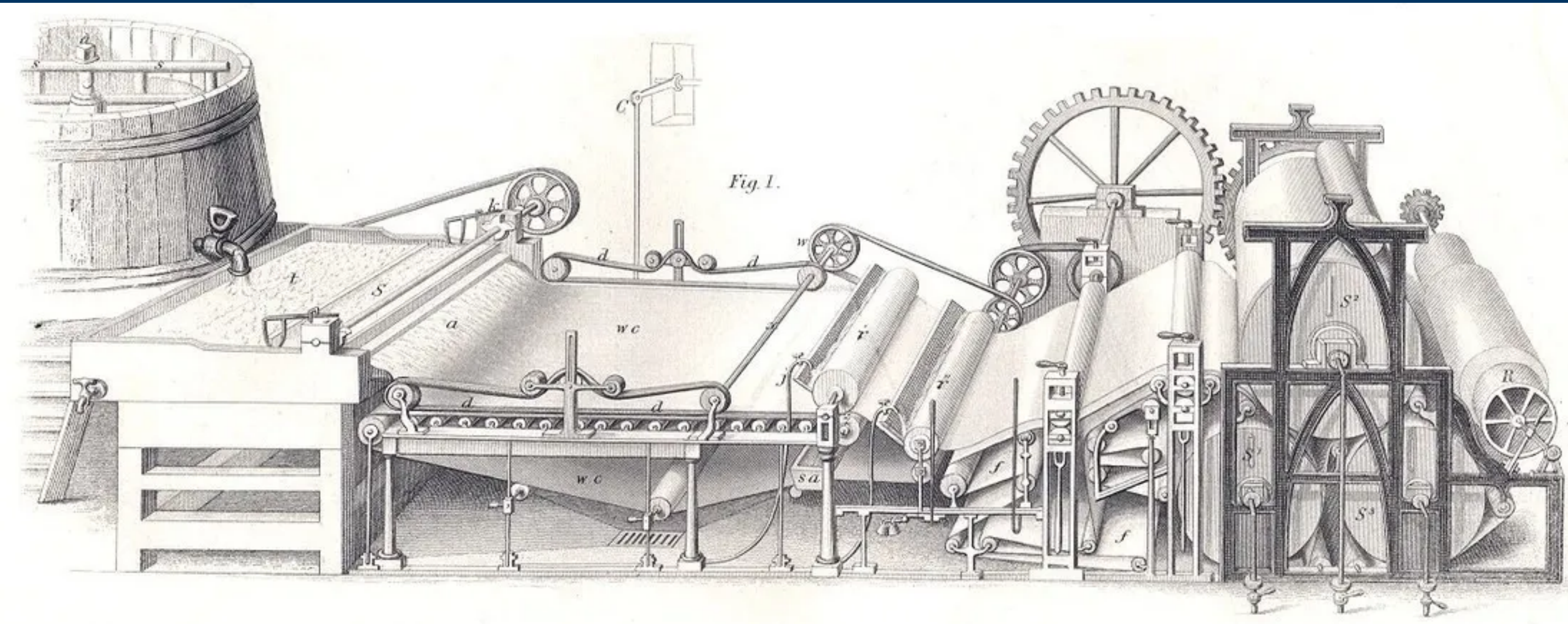

Fourdrinier machine made first large sheets, later continuous rolls of paper. Machine-made papers have direction, or grain.

“Dandy roll” used to
impose texture and/
or watermarks on
machine-made paper

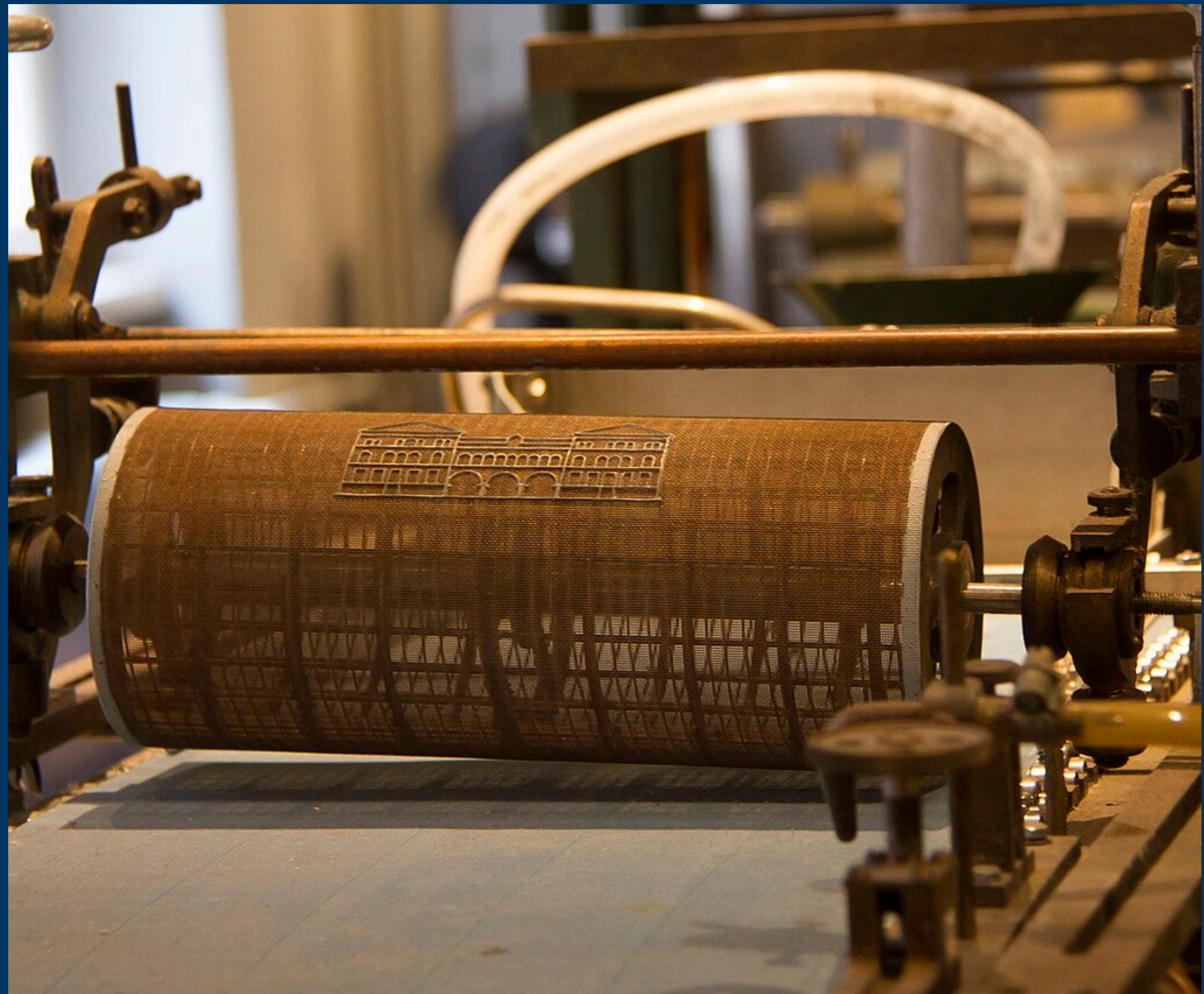

Wood pulp paper

Common from 1840s

Mechanically-pulped wood (1840s-late 19th c.) contains lignin, which breaks down into acidic compounds.

Chemically-pulped wood (20th c.) has lignin removed but chemicals used are themselves acidic.

Alum-rosin sizing on 19th-20th c. papers (replacing gelatin) adds significantly to acidity of paper.

Use of synthetic sizing since 1980s has substantially reduced acidity.

Improvements to the Press

The Stanhope Press, invented ca. 1803 in England:

“The Stanhope is a screw press on which the the screw’s leverage is compounded many times over by a system of levers. Augmenting the power of the press in this way improved upon the design of the wooden hand press, with its single lever used operate the screw.”

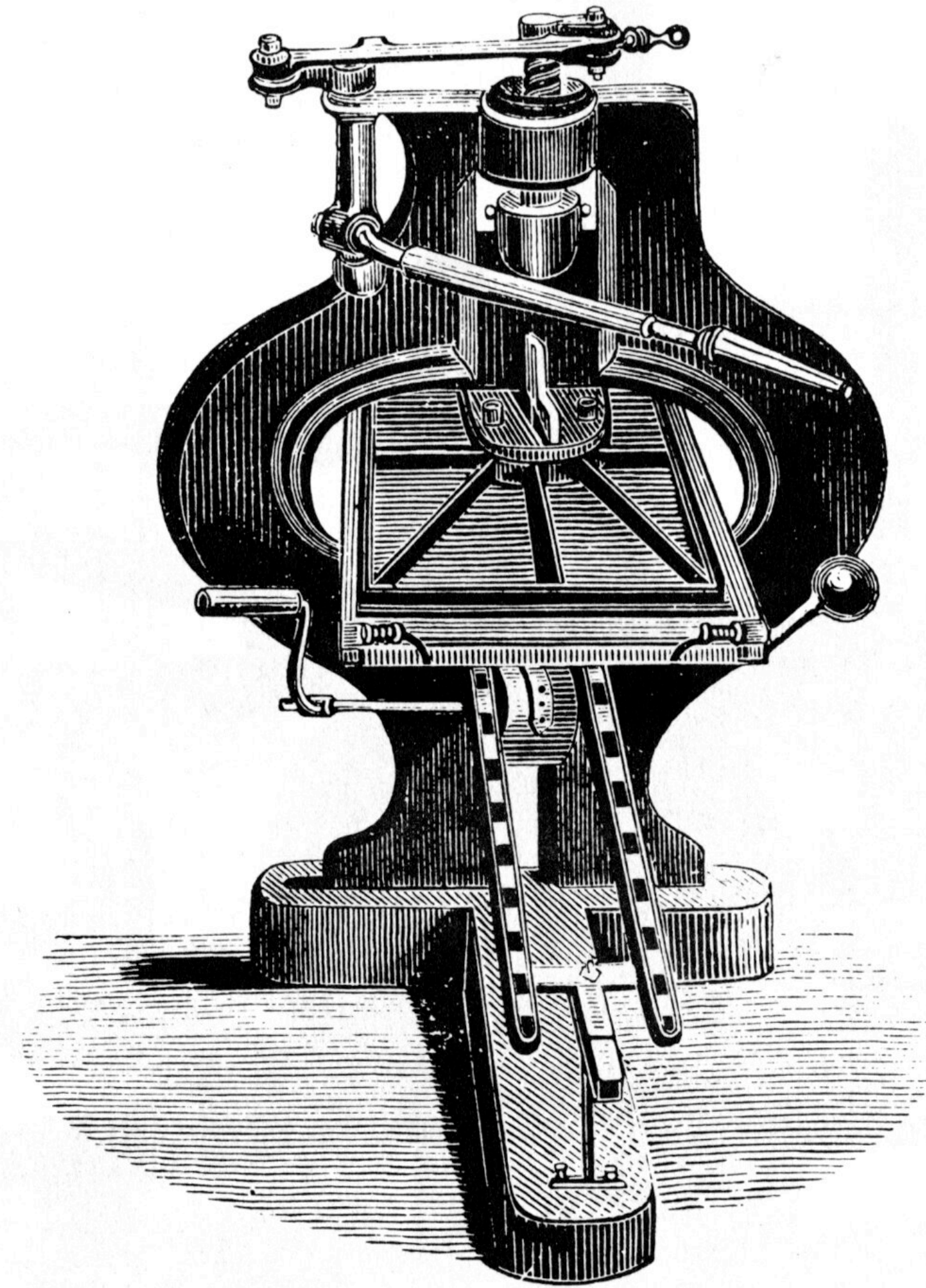

The Stanhope Press. The first all metal hand press was built by Lord Stanhope in England. Circa 1800.



The Washington Press: Invented 1821 in New York by Samuel Rust; manufactured 1830s-early 20th c. by R. Hoe & Co. in both New York and London.

Note large iron platen and lever system to bring it down. These presses were sold in different sizes with options for very large platens, up to 2x3 ft. or more reflecting larger paper sizes available in the 19th century.

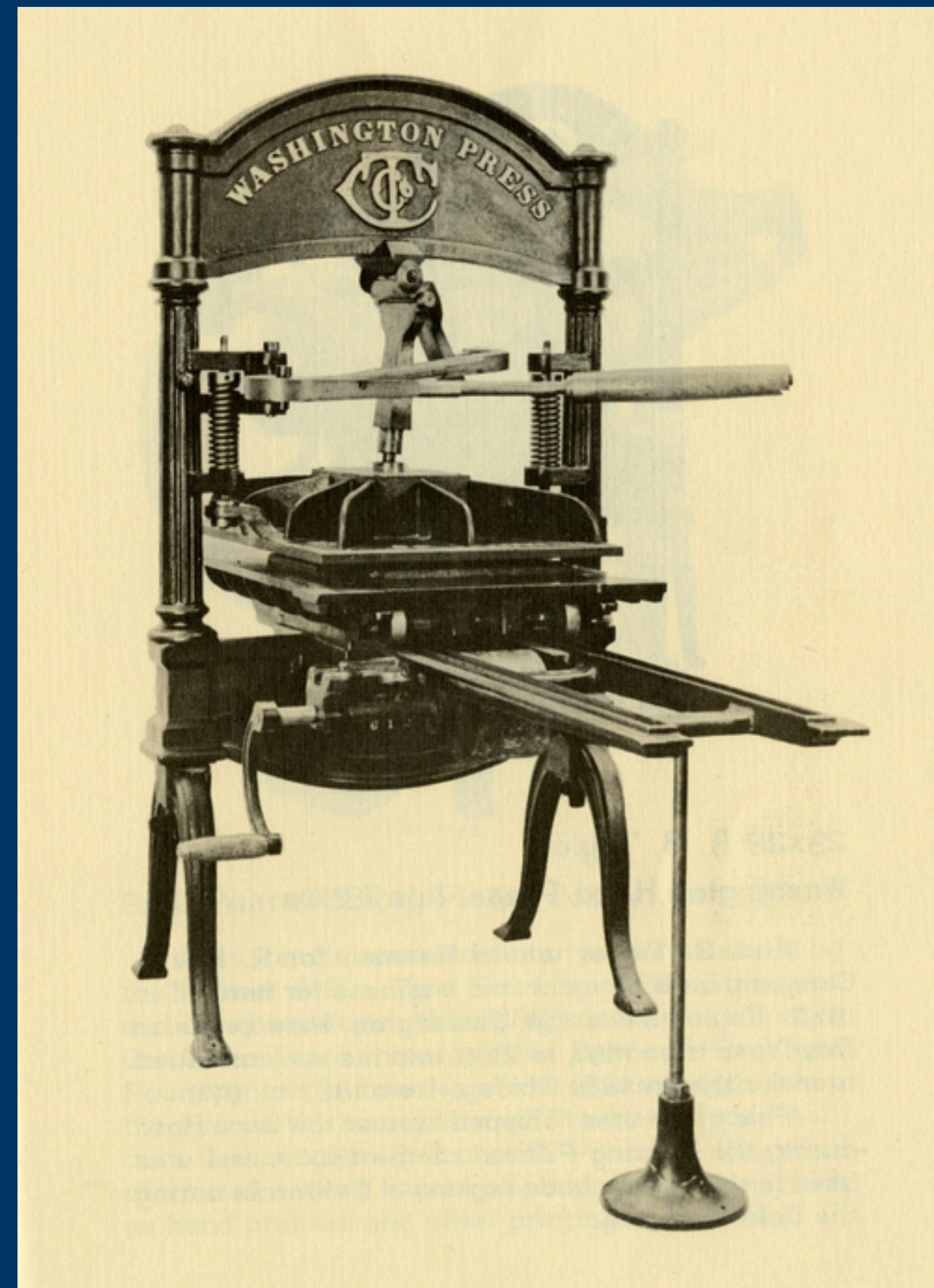

Steam-powered presses: cylinder presses

Friedrich Koenig's cylinder press, 1814

In a cylinder press, the type formes or plates sit on flat beds that slide in for printing, as on a Gutenberg/common press, but the paper is carried over the formes on cylinders.

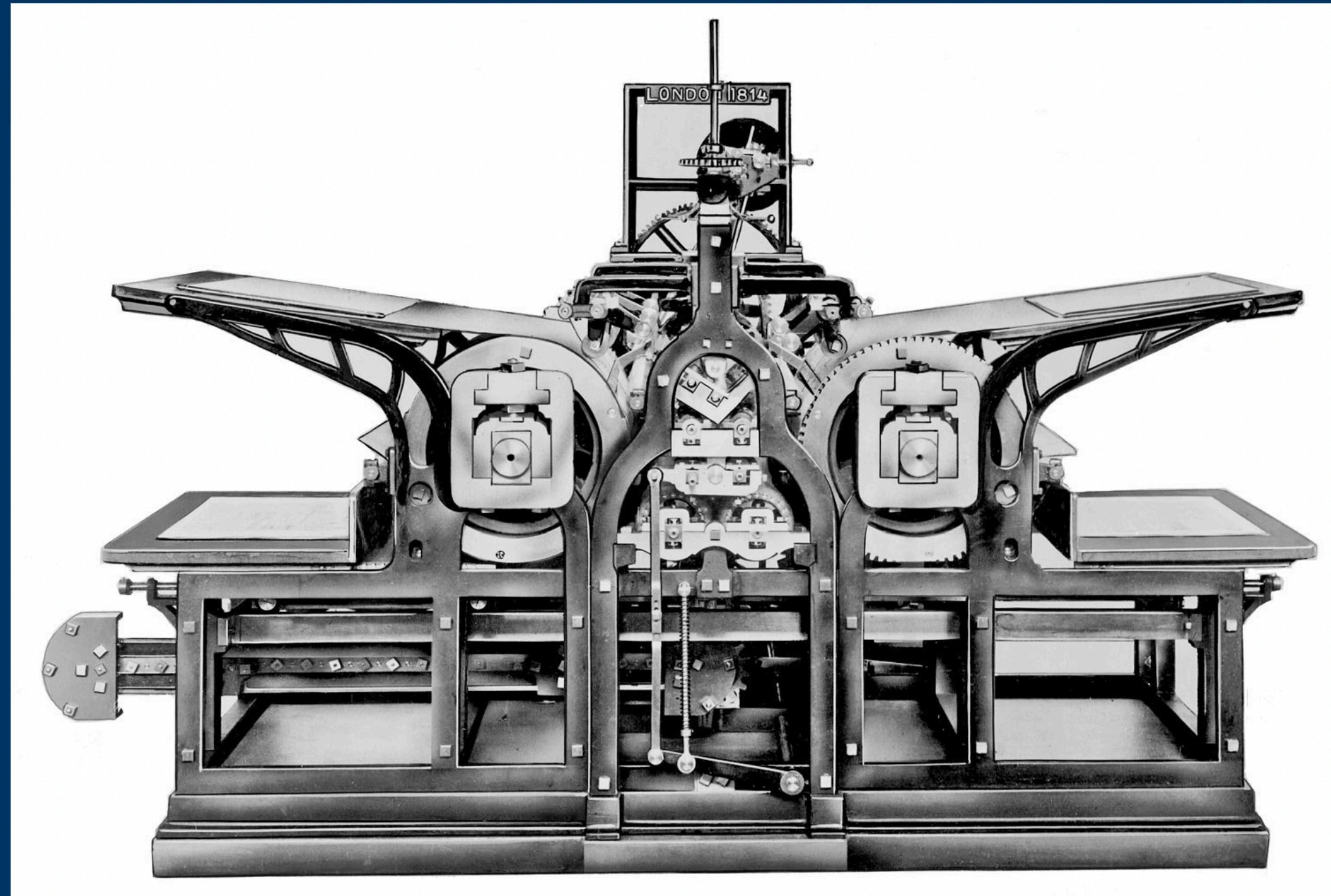

Steam-powered presses: rotary presses

Hoe's rotary press, patented 1847; image from 1860s.

In a rotary press, both paper and plates turn on cylinders.

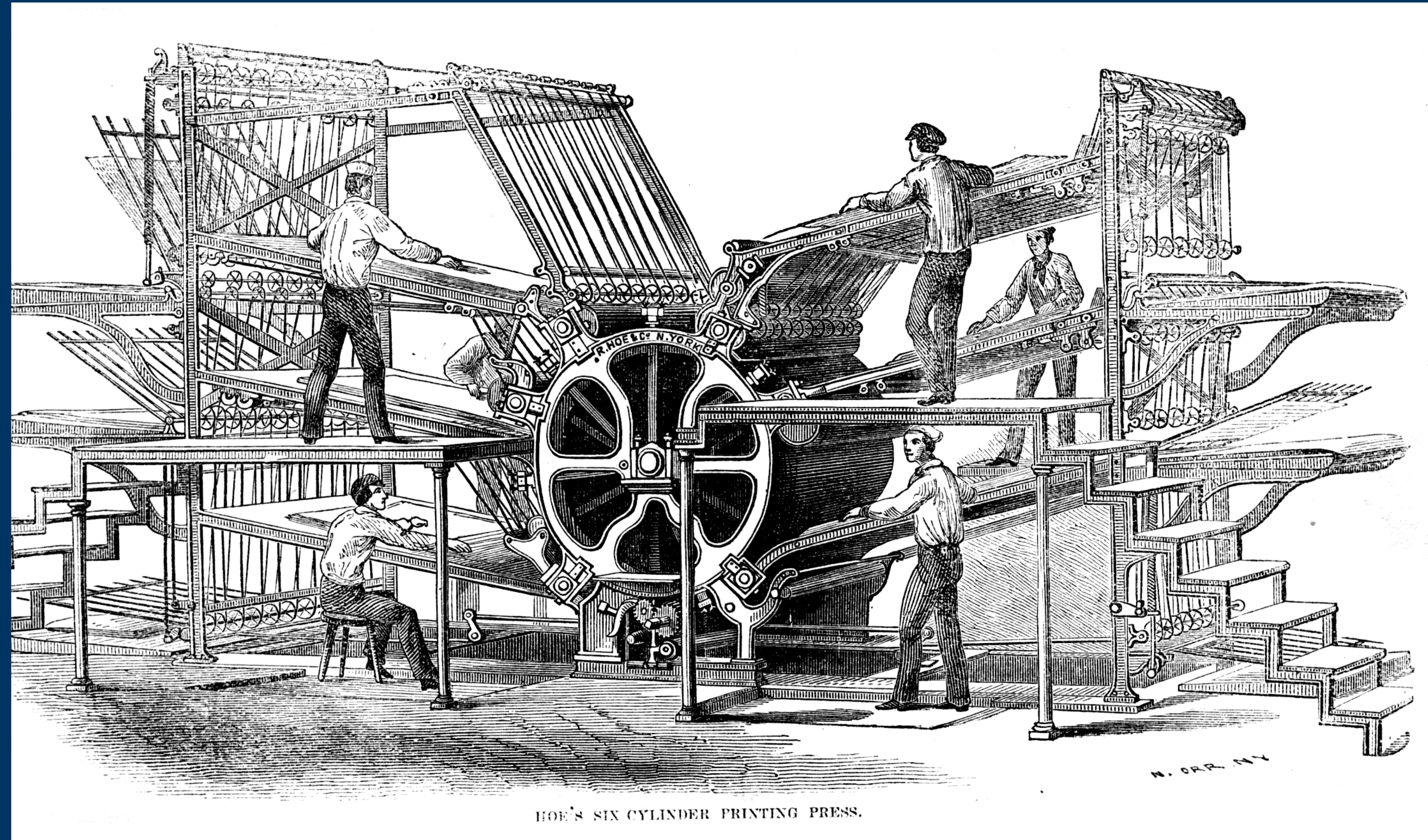

Rotary presses, cont'd: curved stereotyped plates in a rotary press in the New York Times' pressroom, 1942



Changes in binding methods

Medieval and early modern binding technique: **TIGHTBACKED**, in which the cover (spine and boards) are integral with the structure of the book

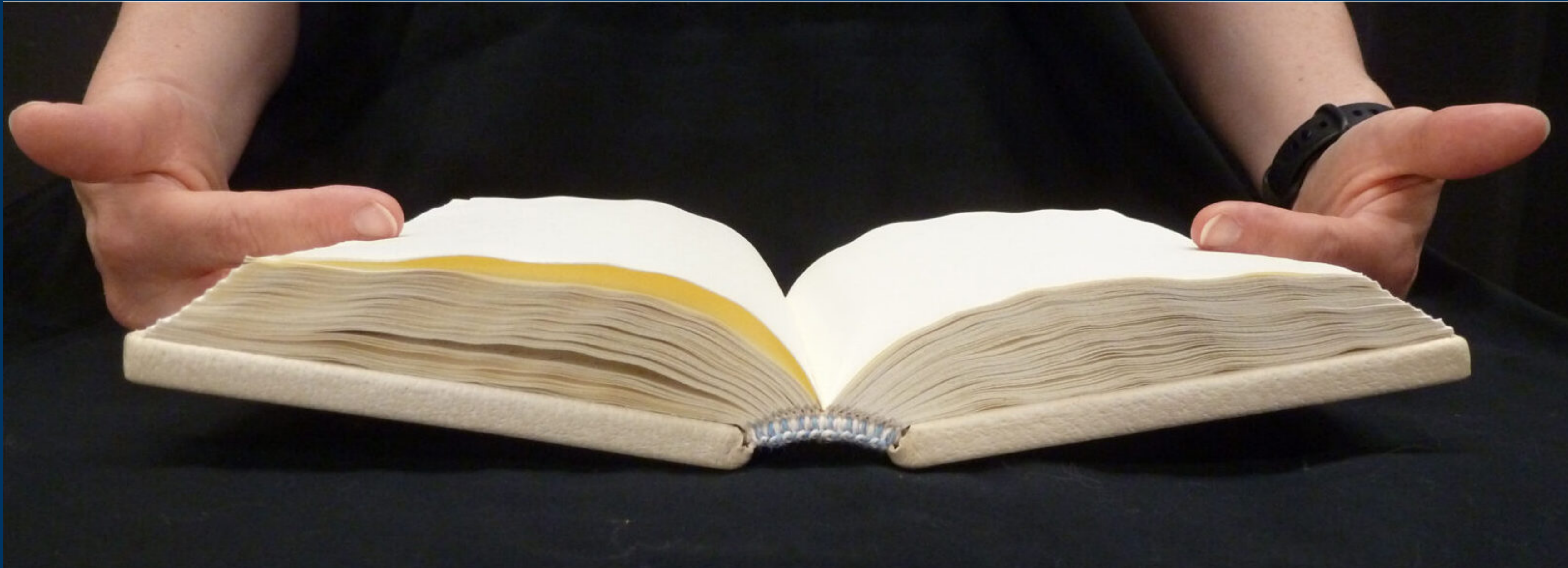



The King James Bible first edition, 1611, in an early binding (Morgan Library)

Note tight-back binding



Case binding, 1820s on: Cover is formed of boards and spine, covered with fabric or other material, and applied to the text block after it is bound. The spine is HOLLOW.

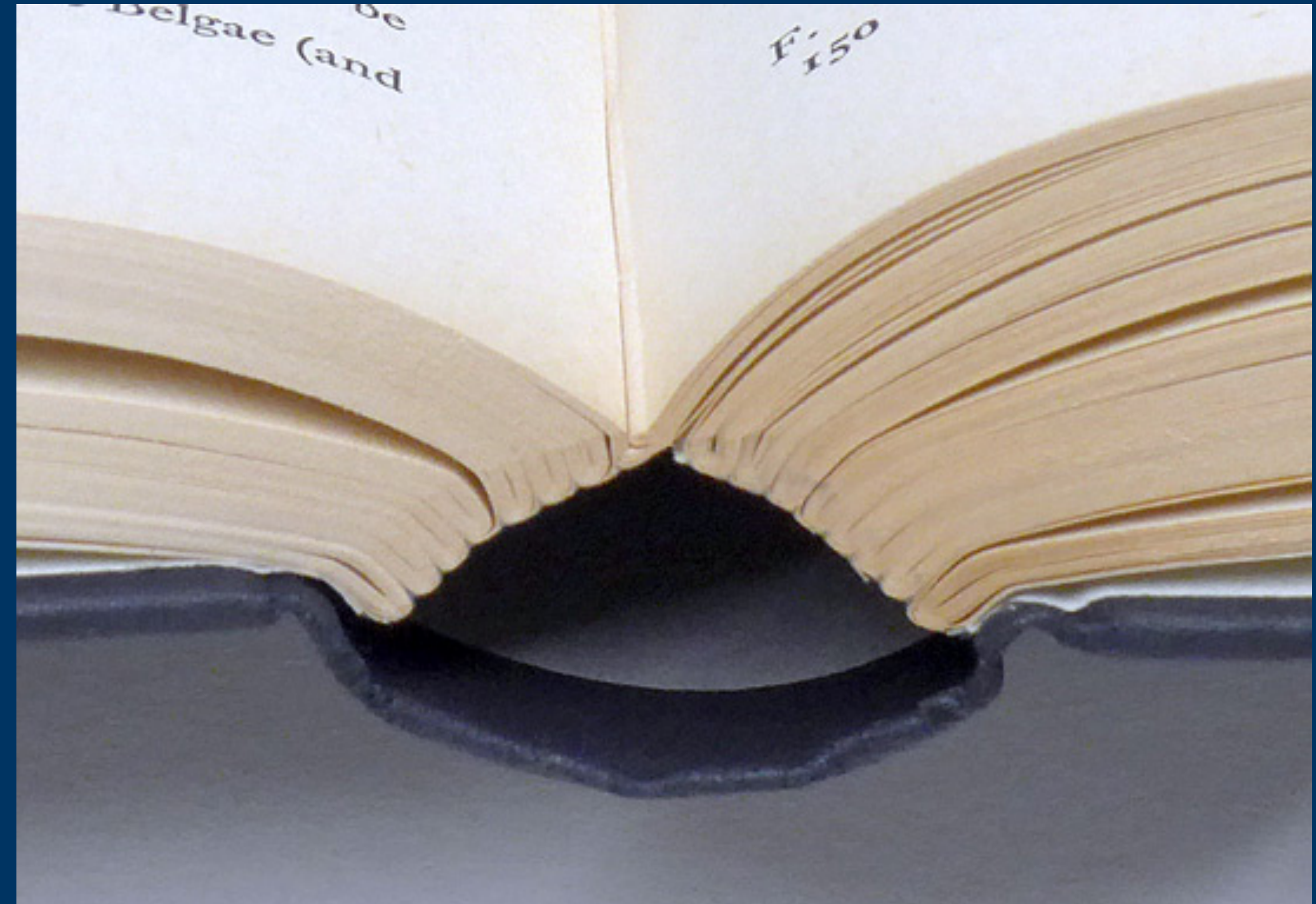
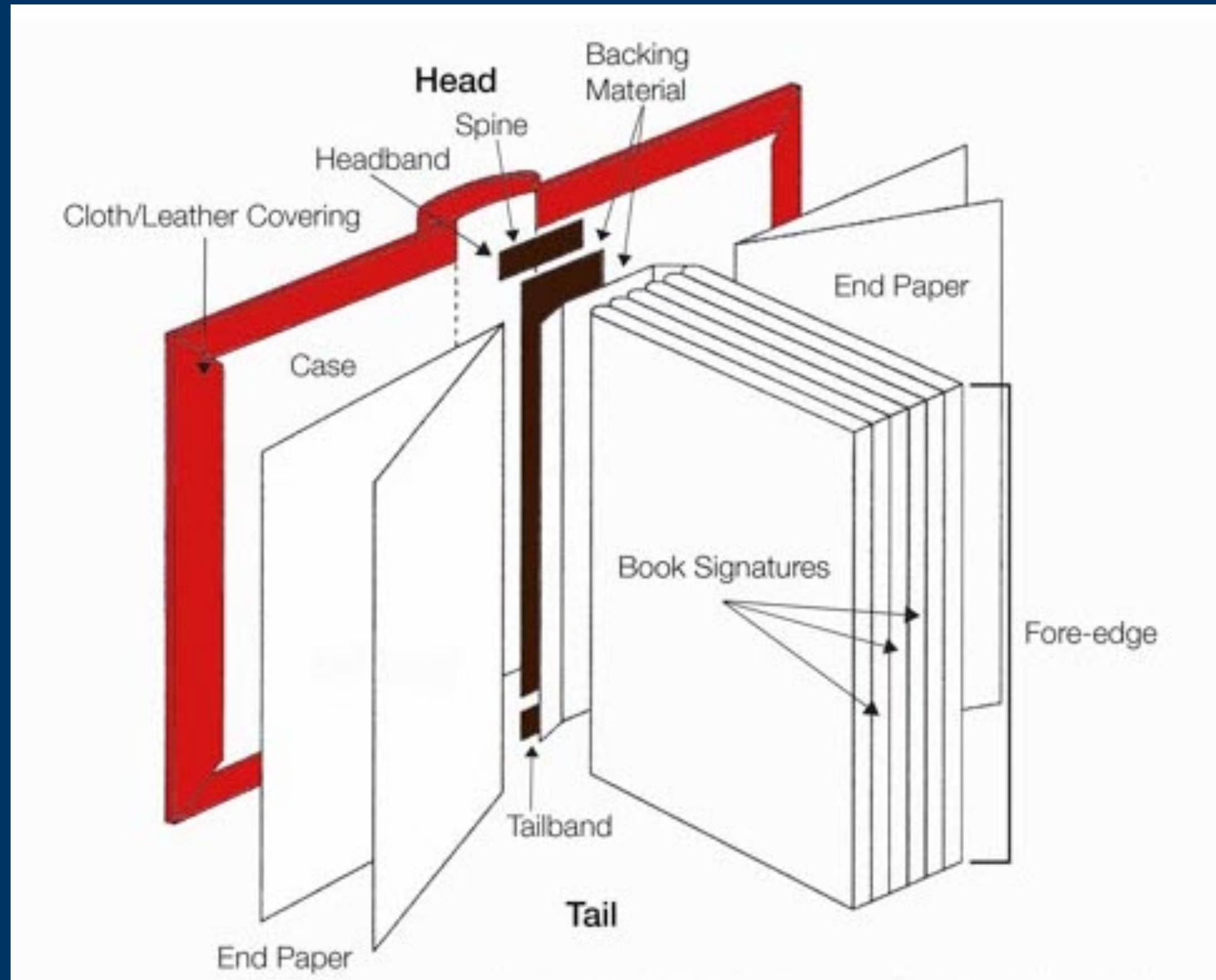

Edition bindings/ publishers' bindings

From 1820s, books were bound by the publisher and sold already bound, which suited the popularization of the market to include people who could not afford to commission private bindings, plus schools, libraries, etc.

Book cloth, invented 1823 by London binder Archibald Leighton: woven cotton, treated to resist glue seepage and stand up to heavy use. The cloth-covered case binding could then be decorated elaborately by machine processes.

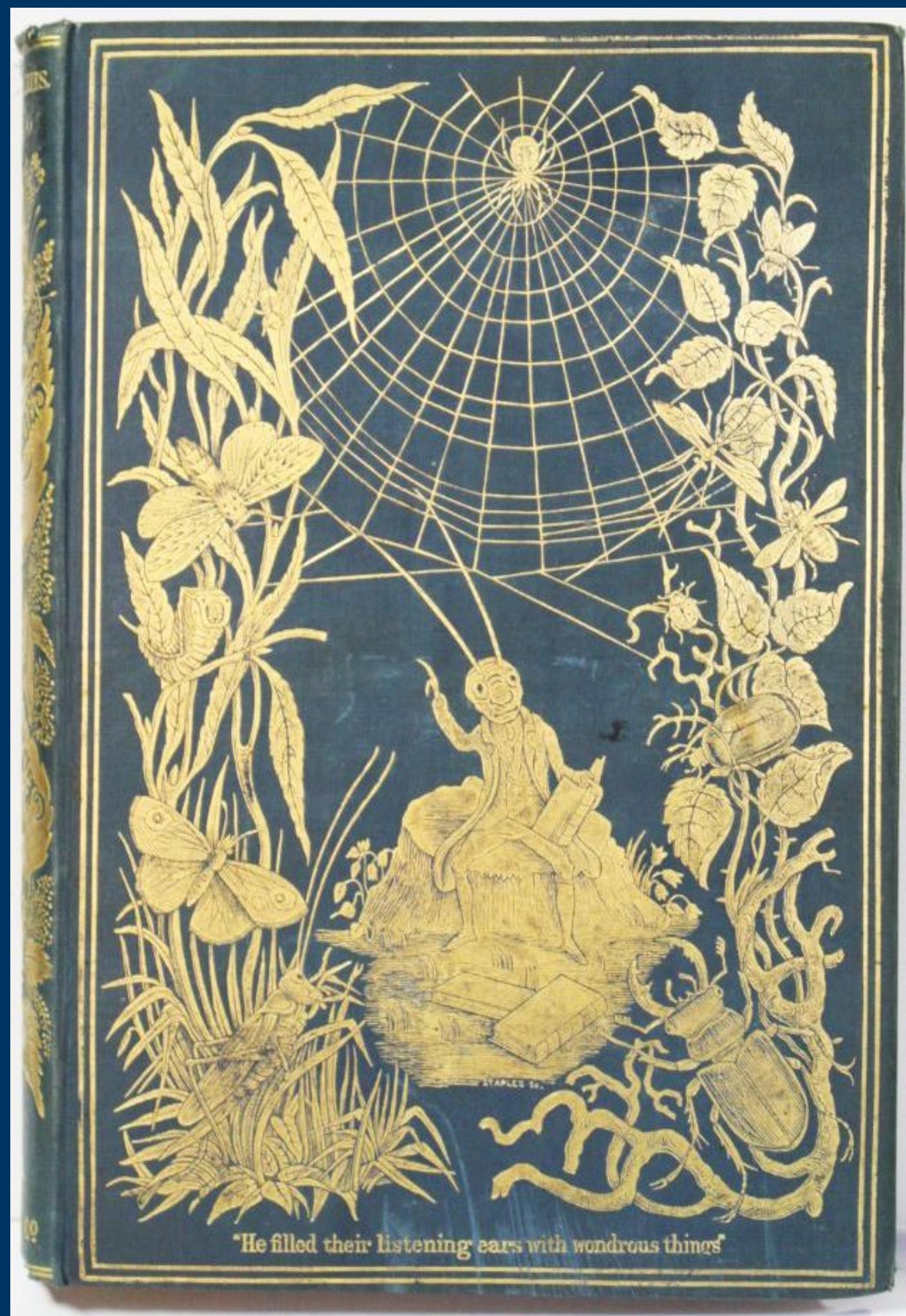

Left: Episodes of Insect Life.
Acheta Domestica (pseud.)
L.M. Budgen. London: Reeve
and Benham. 1849-1851.

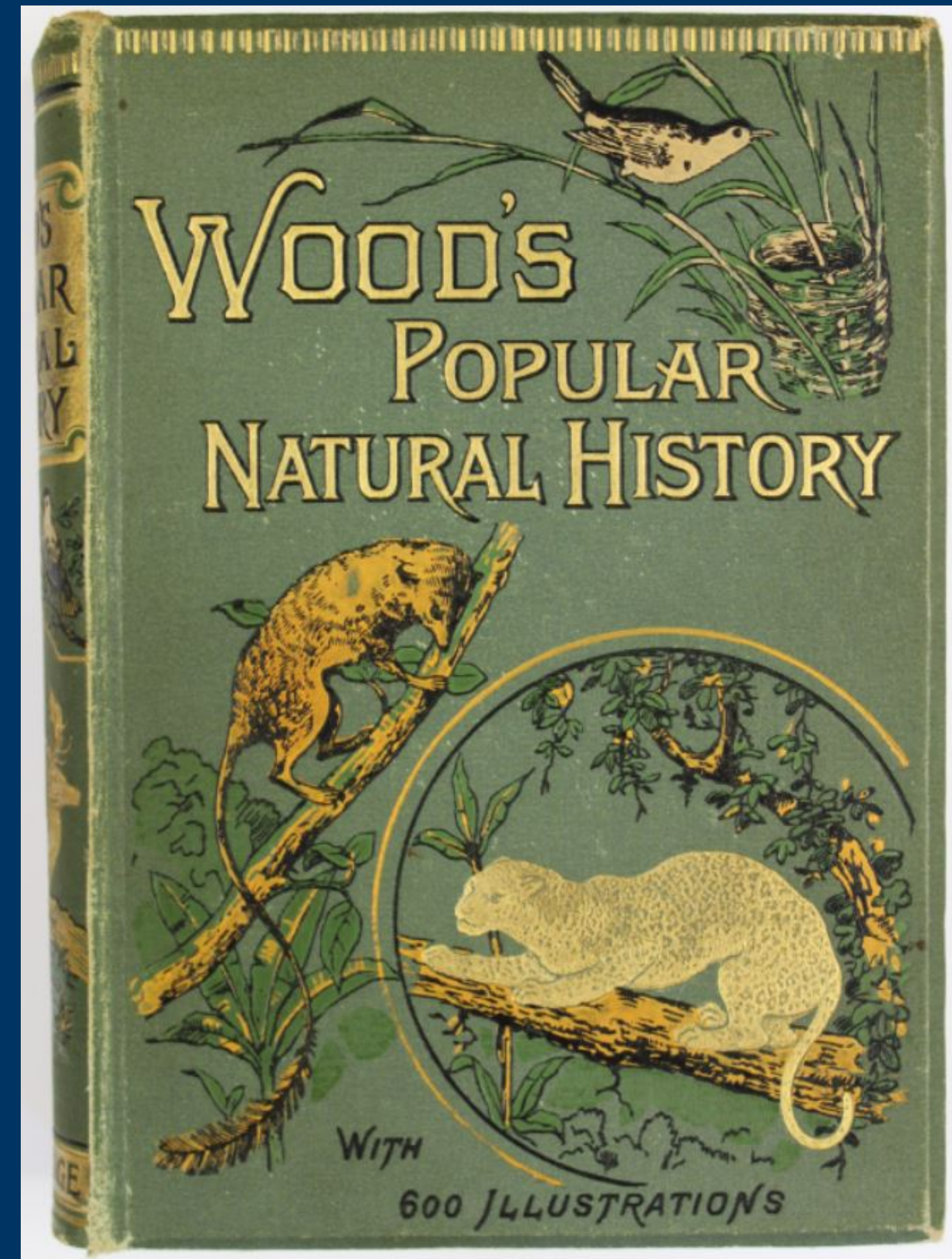

Right: The Popular Natural
History. Rev. J. G. Wood.
London: George Routledge
& Sons. 1892.